

**DTU (Data Transfer Unit)**

**AL5HDTU1**

**<Issuing System for The Hotel Card Lock System AL5H Series>**

**Operations Manual**

**Ver. 0.1**

**August 31, 2003**

**Miwa Lock Co., Ltd.**

## Preface

We thank you and congratulate your choice on becoming an owner of products made by Miwa Lock.

This booklet is the Operations Manual of DTU [AL5HDTU1] (hereinafter referred to as DTU) for the AL5H Series Hotel Card Lock System.

This booklet is divided into the 2 sections consisting of the I Basic Principles and II Operations.

I Basic Principles concerns the basic knowledge necessary to conduct operations and II Operations explains the functions together with the operations that are necessary. First of all, we recommend that you read the I Basic Principles and thoroughly understand the system.

### ○ Our initial request

In operating this system, it is necessary for you to thoroughly understand the special terms and vocabulary used in indications and the special functions of the operations. Errors in the setting up of any functions or provisions and also errors in conducting operations can contribute to deterioration or relapses in security. Therefore it is imperative that you do not hesitate to question us whenever there is a lack of understanding. There should not be any errors or misunderstandings in operations.

### ○ Related Manuals

Besides this manual, we have also prepared the following. Please refer to them as required.

[Maintenance Manual of Issuing Control of Touch Panel Type Cards (AL5H Series of Hotel Card Lock System)]

[Maintenance Manual of Issuing Control of PC Type Cards (AL5H Series of Hotel Card Lock System)]

### ○ Regarding this Manual

- Please refrain from copying or quoting any part of the contents of this booklet without obtaining our prior permission.
  - Any part of the contents of this booklet is subject to change without any prior notice.
  - The contents of this booklet are the result of exhaustive research to eliminate any errors but in the event of discovering any errors or questionable facts, we would appreciate your immediately advising us accordingly.
- 
-

◆ **Precautions**

This system operates on 100 volts AC. Mishaps or accidents such as electrocution, short circuits, fire, etc. and malfunctioning, can be caused if you do not make it imperative to maintain the following precautions.

**(1) Precautions regarding use**

- Do not apply tension upon the cable connected to the DTU.
- Strictly avoid dismantling the DTU.
- Avoid placing anything on top of the DTU as it may lead to malfunctions of the unit.
- The switches contained in the DTU are parts of high precision and should not be impaired by careless spilling of coffee, dropping of clips, pins, or other metal bits of wire, etc. which may cause malfunctioning in any way.

**(2) Precautions regarding operations**

- In order to prevent any operations conducted by unauthorized persons, whenever leaving the DTU, always make sure to 'log off'.

◆ **Precautions concerning operation methods**

**(1) When an input error is indicated**

- When an improper value has been input (when a non-existing room number is entered, etc.), the screen indicates the error. The "ERROR RESET" key is pressed to cancel and erase the erroneous entry and a correct input is made.
- 
-

# CONTENTS

<b>I. Basic Principles .....</b>	<b>I-1</b>
1 Functions outline .....	I-2
2 The overall structure of the connected system.....	I-3
2.1 Diagram of the overall structure .....	I-3
2.2 DTU .....	I-4
3 Names of the respective components .....	I-5
3.1 Indicator.....	I-5
3.2 Operations Unit .....	I-6
4 Starting operations and Ending operations .....	I-7
4.1 Starting operations (Power ON).....	I-7
4.2 START Display .....	I-7
4.3 Ending operations (Power OFF) .....	I-8
5 Sending and receiving data .....	I-9
6 Conducting operations .....	I-10
7 Maintenance .....	I-11
7.1 Charging the battery.....	I-11
7.2 Battery check .....	I-11
7.3 Changing the battery.....	I-11

<b>II. Operations</b> .....	II -1
○ <b>In a case such as this</b> .....	II -2
<b>1 Log-In</b> .....	II -3
1.1 Log-In .....	II -3
1.2 Main menu.....	II -6
<b>2 Normal mode</b> .....	II -7
2.1 Read mode (confirming data) .....	II -7
2.2 Write mode (amending data) .....	II -13
<b>3 Log mode</b> .....	II -20
3.1 Error log.....	II -20
3.2 Interrogation data .....	II -28
3.3 Erasing of the log .....	II -30
<b>4 Special mode</b> .....	II -38
4.1 Emergency reset (EMG RESET) .....	II -38
4.2 Emergency OPEN (EMG OPEN).....	II -40
4.3 MASTER LOCKOUT (ML) .....	II -42
4.4 HOUSEKEEPING LOCKOUT (HL).....	II -44
4.5 LOCKOUT CANCEL (LC) .....	II -46
<b>5 Data transmission mode</b> .....	II -48
5.1 Transmission of interrogation data.....	II -49
■ <b>Error codes and corrective actions</b> .....	II -49
■ <b>Components specifications</b> .....	II -52
■ <b>Where to contact the manufacturers</b> .....	II -52

# I. Basic Principles

Here we shall explain, in undertaking operations of the system, the necessary basic items, the starting and closing down of the system, the movements on the screen, and the basic operation methods involved.

The '1 Functions outline', 'The overall structure of the connected system' is extensively useful to all persons who are connected in any way to the card lock system. Persons who are not engaged in any operating actions of the system but understanding the system more thoroughly, may contribute to its smoother operation.

'3 Names of the respective components' and '4 Starting operations and Ending operations' explain the various operations that the system involves. '6 Conducting operations' indicates by diagrams, the composition of the images involved. Prior to actually operating the system, we recommend that these various chapters be thoroughly read and digested.

<b>1 Functions outline .....</b>	<b>I-2</b>
<b>2 The overall structure of the connected system.....</b>	<b>I-3</b>
<b>3 Names of the respective components.....</b>	<b>I-5</b>
<b>4 Starting operations and Ending operations.....</b>	<b>I-7</b>
<b>5 Sending and receiving data .....</b>	<b>I-9</b>
<b>6 Conducting operations .....</b>	<b>I-10</b>
<b>7 Maintenance .....</b>	<b>I-11</b>

## **1 Functions outline**

When using the AL5H series Card Lock, the DTU is the unit used for setting up the card locks.

The card lock set up information is transmitted and received by infrared ray communication (IrDA) or wired communication (RS-232C) by the touch panel type or the PC type card issuing control unit.

※ This can only be used by the subject hotel.

## 2 The overall structure of the connected system

### 2.1 Diagram of the overall structure

Diagram 1 indicates the overall structure of the system to which the DTU is connected.

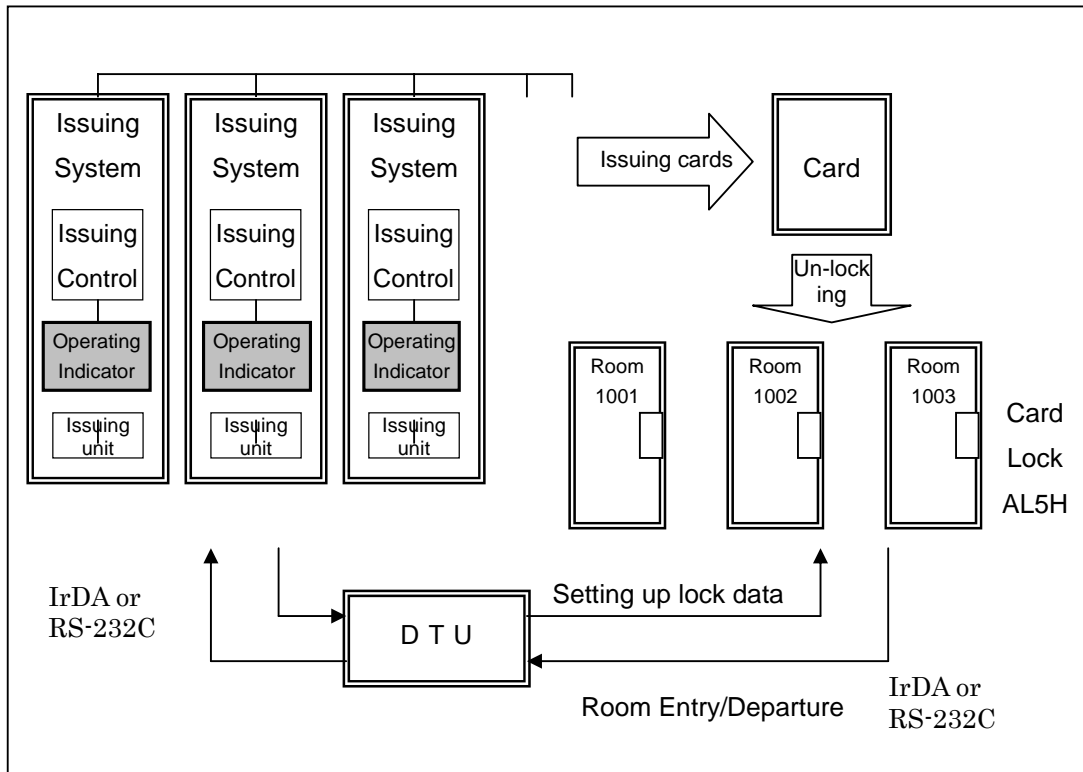

Diagram 1 Overall structure

#### Diagram explained

- Issuing system .....Normally the front desk of the hotel is in charge of issuing the card to be used to unlock the room card lock, using the facility installed at the front desk. This facility consists of the Issuing Control, the Issuing unit, and the Operations Indicator (optional). The issuing system can consist of a plurality of issuing units.
- Cards .....These are the cards that unlock the card locks. They are issued out by the issuing system.
- Card lock .....AL5H Type. This is the room lock that is unlocked only by the cards issued by the issuing system.
- DTU .....Data Transfer Unit. This is the portable terminal that handles the exchange of data between the issuing system and the card lock and is mainly used for maintenance.

## 2.2 DTU

This unit sets up the card lock. The subject unit is illustrated in Diagram 3.



Diagram 3 DTU

- (1) The card lock set up information is received from the issuing control unit via infrared ray communication (IrDA) or wired communication (RS - 232C). The subject set up information can also be transmitted to the card lock.
- (2) At maintenance time it is also possible to refer to the error log or confirm interrogation data.
- (3) Interrogation data that has been extracted from the card lock can also be transmitted to the issuing control unit.

※ The outward appearance of this product is identical to the separate product known as the 'Operations Indicator'.

For customers who are using both units, before putting them into use, we request that you identify them separately by noting the respective labels on their rear sides.

### **3 Names of the respective components**

The respective names of the different parts of the Operations Indicator and their major functions are explained as follows.

#### **3.1 Indicator**

**(1) Liquid crystal display:**

In response to the operation undertaken, the necessary direction for the succeeding operation, and the resulting operation is indicated.

**(2) RUN:**

When the unit is prepared to receive any directions, the LED (green) is illuminated.

**(3) STOP:**

Due to connections having been severed, etc. when the Issuing Control or the Card Issuing Unit cannot be contacted or communicated with, the LED (red) is illuminated.

### 3.2 Operations Unit

The major functions of the operating keys are as follows.

- (1) **[ON / OFF] key:**  
This is used to turn the Power ON or OFF.  
There is no function corresponding to turning the power OFF automatically.
- (2) **[F1] ~ [F5] keys:**  
Used for selecting the respective function and mode.  
It only functions when the selected direction appears on the display indicator.
- (3) **Numerals [0] ~ [9] keys:**  
These keys are used for inputting the respective numerical values.
- (4) **[CLEAR] key:**  
When an input value is to be erased or cancelled.
- (5) **[SHIFT] key:**  
Not to be used.
- (6) **[PRINT] key:**  
Used when printing the log.
- (7) **[ERROR RESET] key:**  
When an error has been made, to erase the error.
- (8) **[ITEM RE - SEL.] key:**  
Operation is erased or cancelled. Returns to the preceding display.
- (9) **[SEND / RCV] key:**  
Used when sending/receiving/transferring the data.
- (10) **SCROLL KEY [▲ ], [▼ ] key:**  
Used for scrolling the display indicator.
- (11) **[ENTER] key:**  
Used when deciding to input or when finishing a process.

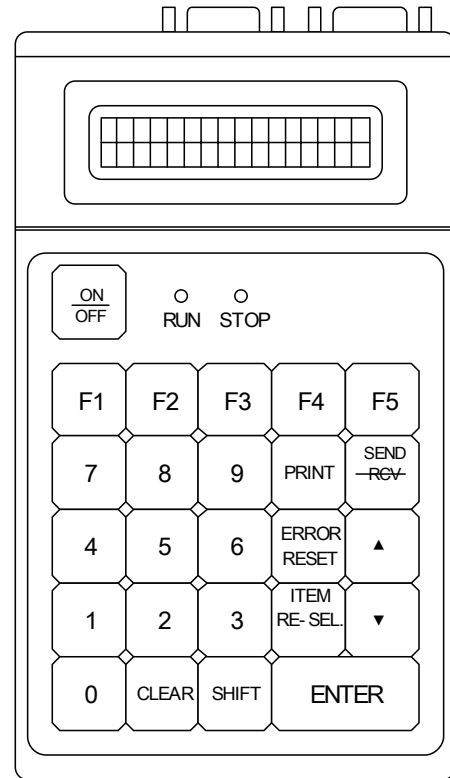

## 4 Starting operations and Ending operations

### 4.1 Starting operations (Power ON)

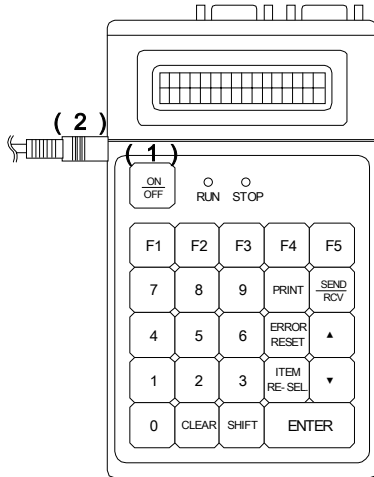

(1) Press the **[ON / OFF]** key.

※ When BATT LOW is displayed, the battery is not charged sufficiently. Either the battery shall be charged or (2) the unit is used with the AC power adapter connected.

(Please refer to "9 Concerning maintenance" for how to charge the battery.)

### 4.2 START Display

#### (1) Indicating the START Display

When the power is normally turned ON, the Log-In Menu Display after the START Display has been indicated. For the succeeding operations, refer to II Operations.

< START Display >

HOTEL SYSTEM



(After about a 1 sec. indication)

< START Display 2 >

HOTEL SYSTEM
AL5H-DTU Ver*****



(After about a 3 sec. indication)

< STAFF CODE entry display >

STAFF CODE [DTU]
→

### 4.3 Ending operations (Power OFF)

End operations in the following order.

- (1) From the respective displays corresponding to operations undertaken, the **[ITEM RE-SEL.]** key is pressed successively a number of times to return to the Main Menu display.

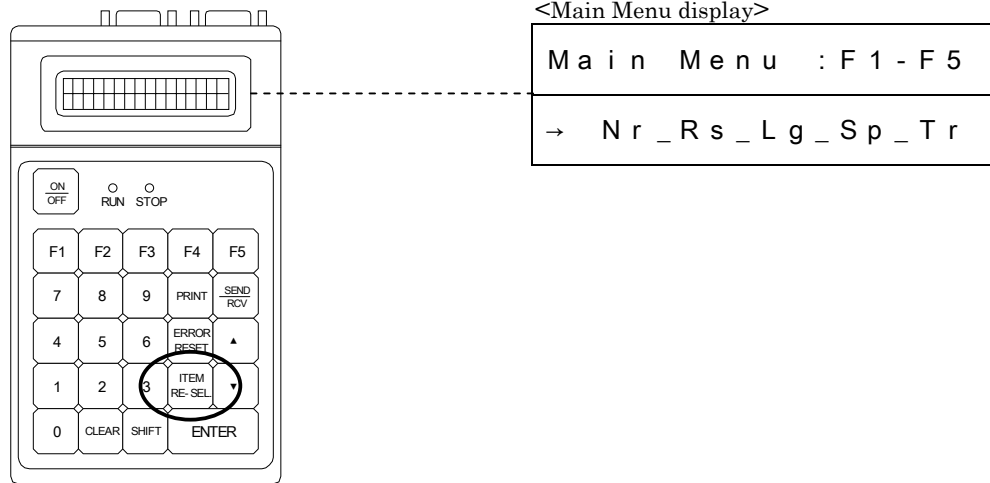

- (3) Confirm that the Main Menu display appears and press the **[ON/OFF]** key.

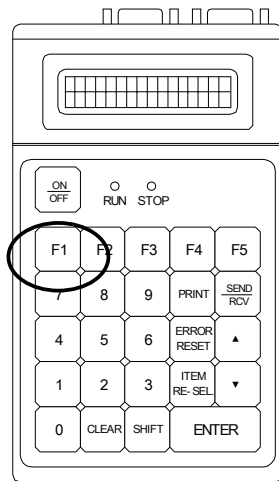

- (3) Confirm that the liquid crystal display has been turned off and terminate operations.

## 5 Sending and receiving data

- (1) Communicating distance: 0 ~ 20 cm
- (2) Communicating angle: Up / Down, Right / Left maximum 15°

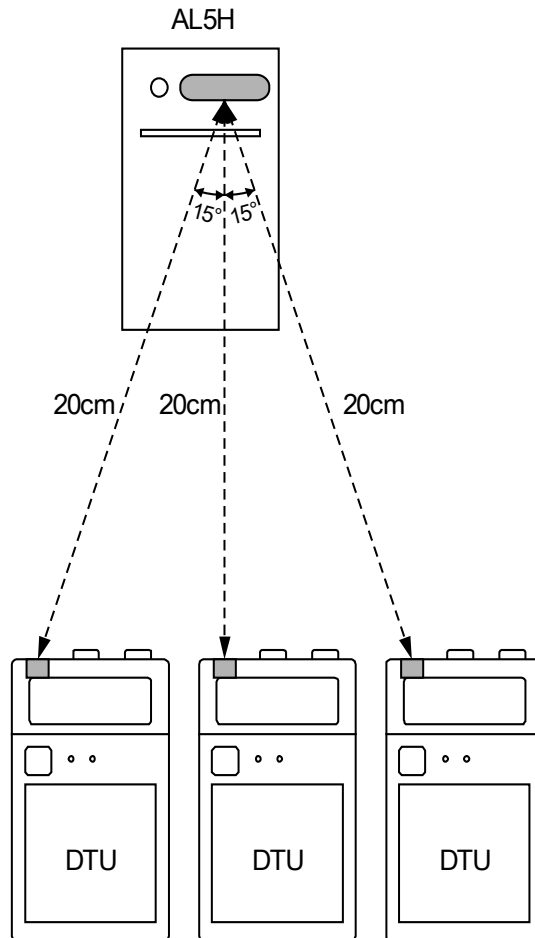
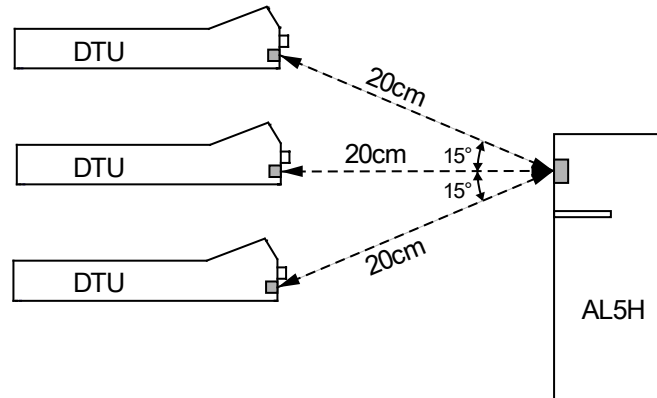

## 6 Conducting operations

The major flow of operations of this unit is as follows. For the explanations of the respective operations, refer to "**II Operations**".

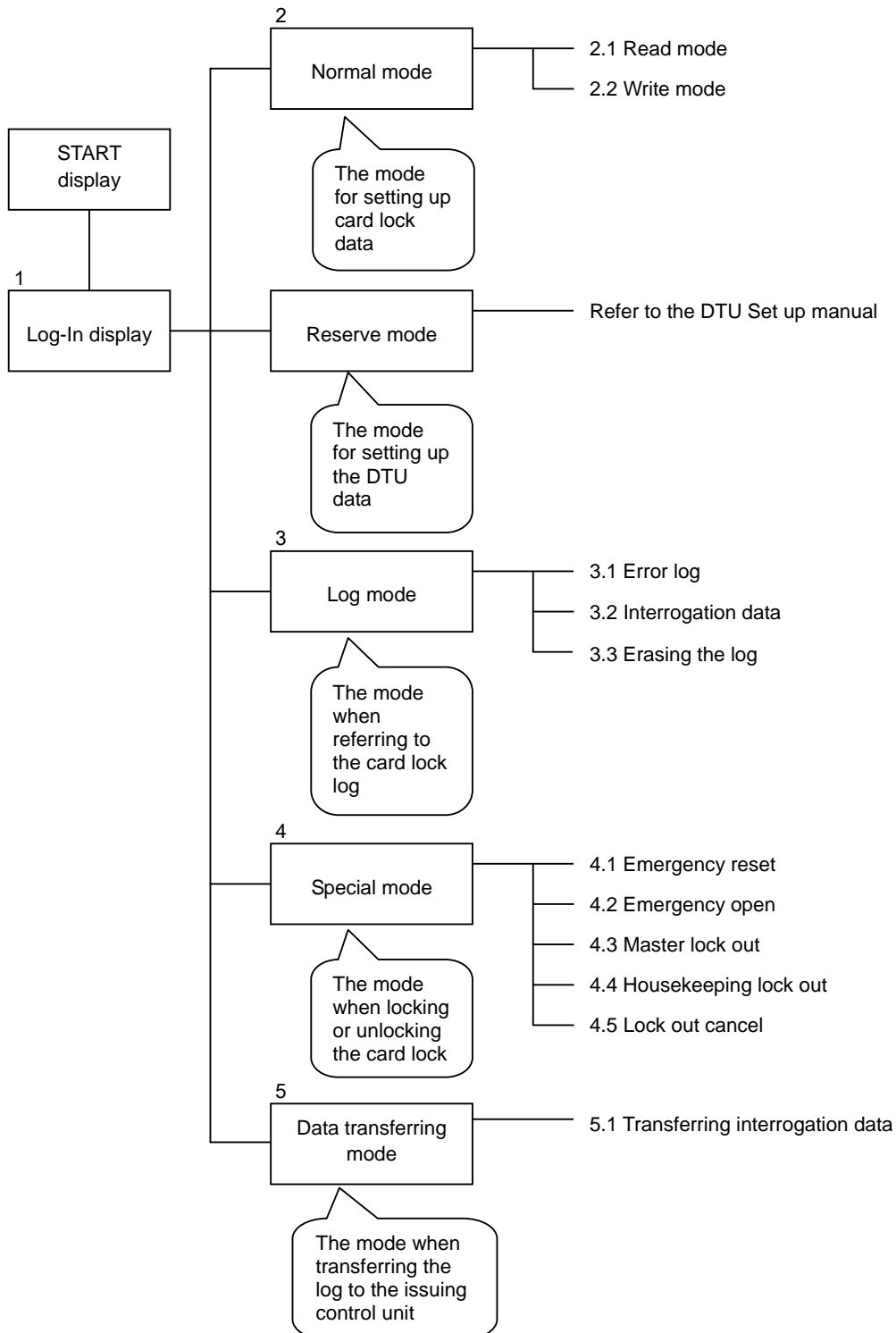

## 7 Maintenance

### 7.1 Charging the battery

- With the plug of the AC power adapter inserted in the receptacle, the AC power adapter is connected to the subject unit.
- Before using the unit, always have the battery charged for a minimum 35 hours.
- With the battery fully charged, the unit can be used continuously for about 3 hours.

### 7.2 Battery check

- Disconnecting the AC power adapter from the unit, put the electric power switch ON.
- The unit is to be operated by the battery so repeat this operation several times.
- If it has been confirmed that the unit operates normally, confirmation is completed.
- When the battery is low on remaining power, BATT LOW is displayed.
- In this case, immediately have the battery charged.

### 7.3 Changing the battery

- When the battery has been sufficiently charged for over 35 hours and the length of time the unit can be battery operated becomes excessively short, you must consider the battery having reached the end of its life.
- The battery must be replaced by a new one.
- Irrespective of the frequency of use, a battery has a limit to its life. In order to maintain the performance of the DTU, we recommend that the battery be replaced every 2 years.

#### Recommended batteries

Manufacturer: YUASA (Yuasa Corporation)

Model: Y - 3 US "AA" TYPE (nickel cadmium battery)

1.2V / 1000 mAh No.3 type Ni-Cd

- Ni-Cd batteries are used so that we request you cooperate in recycling used batteries accordingly.



N i - C d

## II. OPERATIONS

We now explain the functions of the system and its operation.

It is not necessary for you to thoroughly read the contents from start to finish. The text has been prepared so that you can understand the contents if you read only the portion which concerns the operational function you wish to know about.

As the heading "○ In a case such as this..." indicates, we have written about presumed situations of difficulties that may occur so please refer to the respective titles in the contents.

○ In a case such as this .....	II - 2
1 Log-In .....	II - 3
2 Normal mode .....	II - 7
3 Log mode .....	II -20
4 Special mode .....	II -38
5 Data transmission mode .....	II -48

○ **In a case such as this**

- Confirm the setting up data for the card lock.

Follow the instructions in "**2.1 Read mode**" of the Operations Section  
Refer to page II - 8.

- Wish to change the set up data in the card lock.

Follow the instructions in "2.2 Write mode" of the Operations Section.  
Refer to page II - 13.

- The card lock fails to unlock

Follow the instructions in "**3.1 Error log**" of the Operations Section.  
Refer to page II - 20.

For the error concerned, refer to [■ **Error codes and corrective actions**].

- Confirming the history of the use of the card lock

Follow the instructions of "**3.2 Interrogation data**" of the Operations Section.  
Refer to page II - 28.

- Wish to transmit interrogation data of the card lock to the issuing control unit

Follow the instructions in "**5.1 Transmission of Interrogation data**" of the  
Operations Section.

Refer to page II - 48.

## 1 Log-In

Operations from the DTU start up till the Main Menu is displayed.

### 1.1 Log-In

- (1) Turn ON the DTU.
- (2) The display for entering the Staff Code is indicated. (Staff Code is a maximum 6 digit number.)

Example) When the Staff Code is 654321

STAFF CODE [DTU]
->

Press the **[6] [5] [4] [3] [2] [1]** keys in succession.

STAFF CODE [DTU]
-> 654321

654321 is indicated.

Press the **[ENTER]** key.

- (3) The display for entering the Password is displayed. (The Password is a maximum 4 digits.)

Example) When the Password is 1234

PASSWORD
->

Press the **[4] [3] [2] [1]** keys in succession.

PASSWORD
-> ****

The password \* \* \* \* is indicated.

Press the **[ENTER]** key.

- (4) The display for selection of the unit to be used, is shown.

Connect Target ?
R?C -> 1 Ev/C -> 2

**R / C** : Card lock  
(reader controller)  
**Ev / C**: Elevator / Entrance  
(elevator controller)

Press the **[1]** key

- (5) The main menu is displayed.

Main Menu: F1 – F5
-> Nr_Rs_Lg_Sp_Tr

※ **When the Staff Code is incorrect, ERROR is displayed.**

STAFF CODE ERROR

When the **[ERROR RESET]** key is pressed, the display returns to 1. 1 (2).

Re-enter the Staff Code.

※ **When a password is incorrect, ERROR is displayed.**

PASSWORD ERROR

When the **[ERROR RESET]** key is pressed, the display returns to 1. 1 (3).

Re-enter the password.

When the password is incorrectly used 3 times, the power will be automatically disconnected instead of the display returning to 1. 1 (3).

Turn the power ON once more and repeat the operation.

When the staff code is input and reverts to 1 (2), press the **[ITEM RE - SEL.]** key.

※ The function of automatically turning off power

When the display is left ON without anything done for a predetermined time, the power shall be automatically turned OFF. This is a function to prevent the system being used by unauthorized persons.

(From the time of initial set up, you can select whether to have automatic power turned off / or not.)

If the main menu display is left continuously displayed, the power shall be automatically turned off.

When the display is changed from the main menu to another display, the power shall be automatically turned off after a preset time has elapsed and nothing has been done.

## 1.2 Main menu

This is displayed after Log-In. This is the entrance to the respective functions of the subject system.

Main Menu: F1 – F5
-> Nr _ Rs _ Lg _ Sp _ Tr
[ F 1 ] [ F 2 ] [ F 3 ] [ F 4 ] [ F 5 ]

### [F1] : Nr Normal mode

Read mode (refer to Page II - 8)

Write mode (refer to Page II - 13)

### [F2] : Rs Reserve mode

Setting of DTU (refer to DTU set up manual)

### [F3] : Lg Log mode

Error log (refer to Page II-20)

Interrogation data (refer to Page II-28)

### [F4] : Sp Special mode

Emergency reset (refer to Page II - 38)

Emergency open (refer to Page II - 40)

Master lockout (refer to Page II - 42)

Housekeeping lockout (refer to Page II - 44)

Lockout cancel (refer to Page II - 46)

### [F5] : Tr Data transmission mode

Interrogation data transmission (refer to Page II - 48)

## 2 Normal mode

Using the DTU (Data Transfer Unit), the set up information of the card lock is read out and checked.

The flow of the operation is indicated in the following diagram:

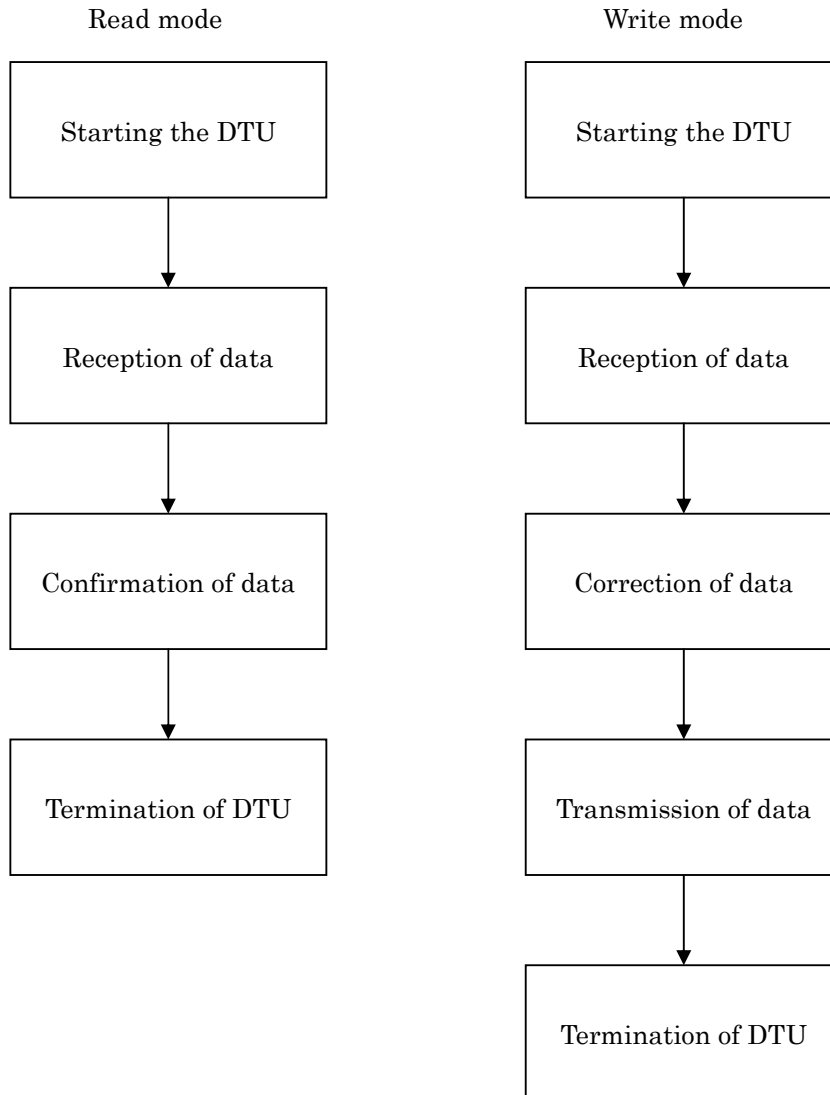

- ※ The card lock of the AL4H design type does not have an infrared ray receiving sensor so that communication with the DTU has an exclusive cable connection. When connected to a card lock and data is to be sent and received, the card is to be semi-inserted in the card reader and after the card reader has been started, press the [SEND / RCV] key.

## 2.1 Read mode (confirming data)

In the Read mode, card lock data is received in transmission.  
This is operated from the main menu.

### 2.1.1 Data reception

Check and confirm that the card lock is in a position to receive transmission of data  
(the red LED of the DTU is lit).

(1) The main menu is displayed.

Main Menu -> F1 – F5
-> <b>Nr</b> _ Rs _ Lg _ Sp _ Tr
[ F 1 ]

Press the **[F1]** key.

(2) The normal mode menu is displayed.

Normal : F1 – F4
-> <b>Rd</b> _ Wr _ Clr _ Data
[ F 1 ]

Press the **[F1]** key.

(3) The confirmation display of receipt of transmission is shown.

READ MODE
PUSH [ SEND/RCV ]

The infrared ray receiving sensor (IrDA) of the DTU is directed toward the  
infrared ray sensor (IrDA) of the card lock and the [SEND / RCV] key is pressed.

Before pressing the **[SEND / RCV]** key, if the **[ITEM RE-SEL.]** key is pressed, the screen display reverts to the normal mode menu 2. 1. 1 (2).

- (4) The DTU receives data transmission from the card lock. During transmission, the following display is shown.

(When the transmission time is short, there are times when the display is not shown.)

READ MODE	← Intermittent blinking (awaiting connection)
TRY CONNECT	

READ MODE	← Intermittent blinking (during transmission)
LOADING	

When transmission receipt has normally ended, the following display is shown.

LOADING SUCCESS
PUSH [ENTER]

Press the **[ENTER]** key.

After receipt of data transmission, the infrared ray sensor (IrDA) may be separated from the infrared ray sensor (IrDA) of the card lock.

- (5) After ending receipt of transmission, the unit displays the previous mode No. (\* \* Division) of the last process in the read mode of the normal mode.

Normal Read
-> R-02

※ When receiving transmission has been aborted, **ERROR** is displayed.

READ MODE
LOADING ERROR

If the **[ERROR RESET]** key is pressed, the display reverts to 2. 1. 1 (3).

### 2.1.2 Confirmation of data

When receipt of transmission of card lock data has ended, the respective data is confirmed.

In the normal maintenance routine, the following 4 items shall be confirmed.

- (a) Room No. R - 02 (Only when the room type is a guest room)
- (b) Current date R - 03
- (c) Current time R - 04
- (d) Unlocking time R - 32

When there is an error, make the correction according to "2.2 Write mode".

- (1) The read mode of normal mode is displayed.

Example) When confirming the Room No. (R - 02)

Normal Read
-> R-02

Press the **[0] [2]** key. <When the Room Type is a Guest Room>

Press the **[0] [3]** key. <When the Room Type is other than a Guest Room>

Proceed to (3)

Normal Read
-> R-02

R - 02 is displayed.

Press the **[ENTER]** key

- (2) The set up value of the Room No. is displayed.

Example) When the Room No. is 101.

R-02 ROOM No.
000101

After confirming the display, press the **[ENTER]** key.

- (3) The current date is displayed. (R - 03)

Example) When it is June 28,

R-03 DATE: mmddyy
03/06/08

After confirming the displayed date, press the **[ENTER]** key.

- (4) The current time is displayed. (R - 04)  
Example) When it is 13 hours 21 minutes 45 seconds

R-04 TIME: hhmmss
14:58:59

After confirming the displayed time, press the **[ITEM - RESEL.]** key.

- (5) The read mode of the normal mode is displayed.  
Example) When confirming the unlocking time (R - 32)

Normal READ
R-04

Press the **[3] [2]** key.

Normal READ
-> R-32

R - 32 is displayed.

Press the **[ENTER]** key.

- (6) The Unlocked time (seconds) is displayed.  
Example) When the unlocking time has been preset as 5 seconds.

R-32 UNLOCK TIME
05

After confirming the displayed time, press the **[ITEM RE - SEL.]** key.

- (7) The read mode of the normal mode is displayed.

Normal READ
-> R-32

<<Effective mode Nos>>

Among the room types set up in the card lock system, there are contents which cannot be processed properly.

Mode No.	Processed content	Room Type		
		Guest	Common	Non-guest
R - 0 2	Room No.	○		
R - 0 3	Date	○	○	○
R - 0 4	Time	○	○	○
R - 0 5	Check-in before time	○	○	○
R - 0 6	Check-out overtime	○	○	○
R - 1 1	Room type	○	○	○
R - 1 2	Room floor	○	○	○
R - 1 3	Range of room		○	
R - 1 5	Non-guest Room No.		○	○
R - 2 1	Type of lock	○	○	○
R - 2 2	IC card set up	○	○	○
R - 2 3	Using magnetic cards	○	○	○
R - 2 4	Dead bolt set up	○	○	○
R - 2 5	Dead bolt over-ride	○	○	○
R - 2 6	Type of buzzer	○	○	○
R - 3 2	Time to unlock	○	○	○
R - 3 3	Effective time as guest		○	○
R - 3 4	Effective days as guest		○	○
R - 3 6	Summer time	○	○	○
R - 3 7	Auto time zone		○	○
R - 4 2	Range of rooms (elevator controller)		※	
R - 4 3	Contact No.		※	
R - 4 4	Time to make contact		※	
R - 4 5	EM operation		※	

※ When the initially set mode of the elevator controller is effective on the card lock system, it becomes possible to conduct the processes R - 42 ~ R - 45.

## 2.2 Write mode (amending data)

When mistakes occur in the "2. 1 Read mode", data is amended or corrected with the Write mode. Prior to amending or correcting data, the card lock data is received in transmission.

This is processed from the main menu.

1

### 2.2.1 Data transmission receipt

Confirm that the card lock is in a mode compatible to transmission (the red LED of the DTU is lit).

- (1) The main menu is displayed.

Main Menu: F1 – F5
-> Nr _ Rs _ Lg _ Sp _ Tr

[ F 1 ]

Press the **[F1]** key.

- (2) The normal mode is displayed.

Normal : F1 – F4
-> Rd _ <b>Wr</b> _ Clr _ Data

[ F 2 ]

Press the **[F2]** key.

- (3) The data transmission receipt confirming display appears.

WRITE MODE
PUSH [ SEND / RCV ]

The DTU infrared ray sensor (IrDA) is directed towards the card lock infrared ray sensor (IrDA). Press the **[SEND / RCV]** key.

Before pressing the [SEND / RCV] key, if the **[ITEM RE - SEL.]** key, if the **[ITEM RE - SE.]** key is pressed, the display reverts to normal mode menu 2. 2. 1 (2).

- (4) The DTU receives data transmission from the card lock.  
During transmission, the following display is shown.  
(When the transmission time is short, there are times when the display does not appear.)

WRITE MODE	← intermittent blinking (awaiting connection)
TRY CONNECT	
WRITE MODE	← intermittent blinking (during transmission)
LOADING	

When reception normally ends, the following display appears.

LOADING SUCCESS
PUSH [ ENTER ]

Press the **[ENTER]** key.

After receipt of transmission, the infrared ray sensor (IrDA) of the DTU can be separated from the infrared ray sensor (IrDA) of the card lock.

- (5) After ending receipt of transmission, the unit displays the previous mode No. (\* \* Division) of the last process in the read mode of the normal mode.

Normal WRITE
-> W **

※ When receiving transmission has been aborted, **ERROR** is displayed.

WRITE MODE
LOADING SUCCESS

If the **[ERROR RESET]** key is pressed, the display reverts to 2. 1. 1 (3).

### 2. 2. 2 Amendment of data

Input the Mode No. that is to be amended and amend the data. The mode No. is as follows.

- (a) Room No.                      W - 02 (only when the room type is a guest room)
- (b) Current date                  W - 03
- (c) Current time                  W - 04
- (d) Unlocking time                W - 32

(1) The Write mode display of normal mode is displayed.

Example) When amending the Room No. (W - 02)

Normal WRITE
→ W - * *

Press the **[0] [2]** key. <When the room type is a guest room>

Press the **[0] [3]** key. <When the room type is other than a guest room> Proceed to (4)

Normal WRITE
W 02

W - 02 is displayed.

Press the **[ENTER]** key.

(2) The set up value of the Room No. is displayed.

Example) When Room No. 101 is set up

W 02 ROOM No.
000101

When the **[ITEM RE - SEL.]** key is pressed, the display reverts to the write mode of the normal mode menu 2. 2. 2 (1).

(3) The Room No. is amended.

Example) When it is to be amended to Room No. 205.

W 00 ROOM No
00101

Press the **[2] [0] [5]** keys.

W 00 ROOM No
005

Press the **[ENTER]** key.

Without input of the set up value, in the **[ENTER]** key is pressed, data shall not be amended. Will proceed to the next mode No. (in this case W - 03).

The set up value of the Room No. and confirmation display of the amendment is displayed.

W 00 ROOM No
00005 OK

When making the amendment, press the **[ENTER]** key.

When the amendment is to be erased or re-input, press the **[CLEAR]** key.

The display shall revert to the present Room No. set up value 2. 2. 2 (3).

The Room No. set up value after amendment shall be displayed.

W 00 ROOM No
00005

When the amendment is confirmed, proceed to the 2. 2. 3 Transmission of data.

- (4) When successively other modes are to be amended, **[ITEM RE-SEL.]** key when pressed, the display reverts to the former write mode of normal mode 2. 2. 2 (1).

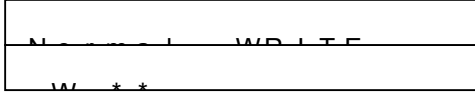

Input the Mode No. for which you wish to have the set up value amended  
For the succeeding operations, repeat the operations listed under 2. 2. 2 (1) ~ (3).

### 2.2.3 Transmission of data

After the end of any amending, the set up data is transmitted to the card lock.

- (1) At the time of ending amendments , the [SEND / RCV] key is pressed.
- (2) The display for confirming amended data is shown.



The DTU infrared ray sensor (IrDA) is aimed at the infrared ray sensor (IrDA) of the card lock and the [SEND / RCV] key is pressed.

Prior to pressing the [SEND / RCV] key, if the [ITEM RE - SEL.] key is pressed, the display reverts to the normal menu 2. 2. 1 (2).

- (3) Data is transmitted from the DTU to the card lock.  
During transmission, the following display is shown.  
(When the transmission time is short, there are cases when the display is not shown.)

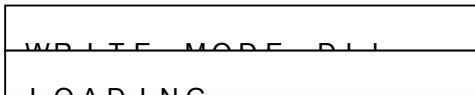
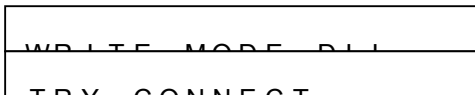

When transmission normally ends, the following display is shown.

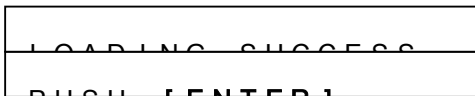

Press the [ENTER] key.

After transmission of data, the DTU infrared ray sensor (IrDA) can now be separated from any connection with the infrared ray sensor (IrDA) of the card lock.

- (4) After ending transmission, the display indicating the end of amendments is shown.

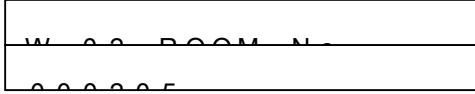

Press the **[ITEM RE - SEL.]** key several times and revert to the normal mode menu.

The normal mode menu is now displayed.

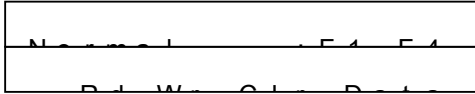

※ When there is failure in transmission, **ERROR** is displayed.

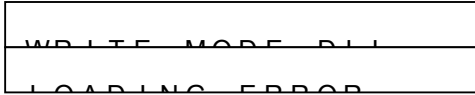

Press the **[ERROR RESET]** key to return to the 2. 2. 3 (2) display.  
Once again set up data can now be transmitted.

The log is transmitted from the card lock to DTU.

Despite transmitting the log, the card lock log remains without being erased and the log can be transmitted from the card lock as many times as necessary.

The operation is executed from the main menu.

### 3.1 Error log

The card lock records up to 40 of the most recent card operations that have become errors. Using the DTU, it is possible to search for items recorded in the error log.

Also data covering a maximum 16 rooms (card lock) can be recorded.

#### 3.1.1 Transmission of error logs

Error logs are transmitted from the card locks.

- (1) The main menu is displayed.

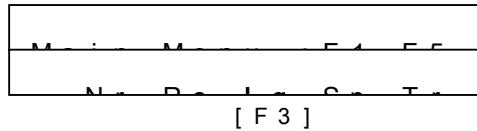

Press the **[F3]** key.

- (2) The log mode menu is displayed.

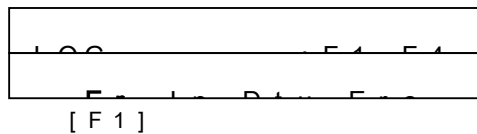

Press the **[F1]** key.

- (3) The error log is displayed.  
The data storage number and the contents are displayed, corresponding to the most recently processed error log mode of preceding cases.

In the case of data already placed in storage.....The room type or Room No. (In the case of guest rooms)

SELECT DATA No.
01-000101

In the case of storage space being vacant

SELECT DATA No.
01-EMPTY

In the case of storage space being vacant (EMPTY), error logs can be transmitted there.

※ When data has already been transmitted to a storage destination, data for storage cannot be transmitted from the card lock. Select another viable data storage number.  
When referring to data already placed in storage, press the **[ENTER]** key and the unit will proceed to 3. 1. 2 error log confirmation.

- (4) Select an empty data storage number from 01 to 16.  
Example) When an error log is to be stored in storage number 10.

SELECT DATA No.
01-000101

Press the **[▲]** **[▼]** key.

Storage No. 10 is displayed.

SELECT DATA No.
10-EMPTY

Press the **[ENTER]** key.

- (5) The display for confirmation of transmission of data is displayed.



The infrared ray sensor (IrDA) of the DTU is aimed at the infrared ray sensor (IrDA) of the card lock and the **[SEND / RCV]** key is pressed.

Prior to pressing the **[SEND / RCV]** key, press the **[ITEM RE - SEL.]** key and the display reverts to 3. 1. 1 (2).

- (6) The data is transmitted from the DTU to the card lock.  
During transmission, the following is displayed.  
(When transmission time is short, there are times when this is not displayed.)

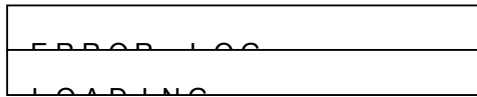
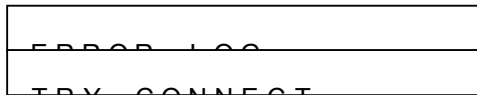

When transmission normally ends, the following is displayed.



Press the **[ENTER]** key.

After data transmission, the infrared ray sensor (IrDA) of the DTU can be separated from the infrared ray sensor (IrDA) of the card lock without any trouble arising.

- (7) After ending transmission , the error log selection image is displayed.

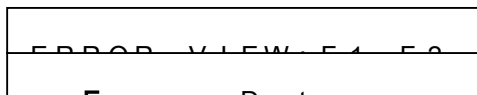

※ When transmission failure occurs, ERROR is displayed.

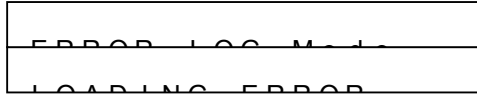

When no data could be transmitted whatsoever, when transmission failure occurred during transmission, if the **[ERROR RESET]** key is pressed, the display reverts to 3.

1. 1 (5).

※ When transmission failure occurs, ERROR is displayed.

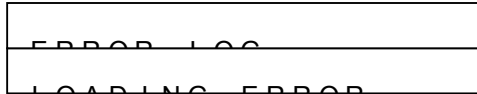

When no data could be transmitted whatsoever, when transmission failure occurred during transmission, if the **[ERROR RESET]** key is pressed, the display reverts to 3.

1. 1 (5).

### 3. 1. 2 Confirmation of error log

The error log transmission is searched and the contents confirmed.

- (1) When transmission is ended, the error log selection display is shown.

ERROR VIEW: E1 E2
Error Data
[ F 1 ]

Press the **[F1]** key.

In the error log mode display 3. 1. 1 (3) when the selection of the storage number has been selected for data that is being transmitted, this shall be shown in the display.

- (2) The data search display appears.  
The current time and date is displayed.  
If this is satisfactory as is, press the **[ENTER]** key.

When the time and date to be searched is designated, input the time and date to be sought.

Example) When the search commences from June 28, 2003:

SET DATE RANGE
F 03Y / 06M / 28D

Press the **[0] [3] [0] [6] [2] [8]** keys.

SET DATE RANGE
030608

030608 is displayed

Press the **[ENTER]** key.

Example) When the date at the end of the search is June 30, 2003.

```

SET DATE RANGE
T 00Y/00M/00D
  
```

Press the **[0] [3] [0] [6] [3] [0]** keys.

```

SET DATE RANGE
030630
  
```

→ 030630 is displayed.

Press the **[ENTER]** key.

- (3) When a plurality of lines of text are involved, with the **[▲]** **[▼]** keys, scrolling is displayed.

The contents of the error logs are displayed.

Within the search limits designated, the latest data shall be displayed.

Example) The number of items / the total number of items and the breakdown of card types is displayed.

```

SEARCH LOG 101/101
SEARCH QUA
  
```

Press the **[▼]** key.

The time of the operation and the error code is displayed.

```

SEARCH LOG 101/101
SEARCH QUA
  
```

Press the **[▼]** key.

The contents of the ERROR and the maintenance code is displayed.

```

SEARCH LOG 101/101
SEARCH QUA
  
```

Press the **[▼]** key.

The following error log contents is displayed. (a maximum 40 items displayed.)

When displaying the error log data, if the [ITEM RE - SEL.] key is pressed twice, the display reverts to the error log storage No. selection display 3. 1. 1 (4).

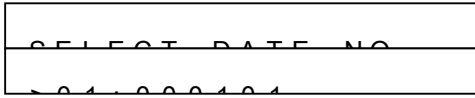

When showing the error log storage No. selection display, the [ITEM RE - SEL.] key is pressed, the display reverts to the log mode menu.

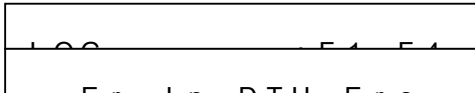

<<Error log examples>>

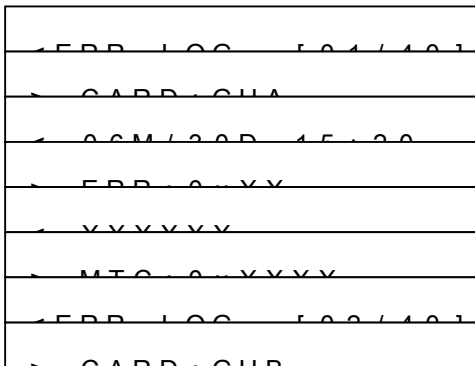

- Number of items / Total number (up to the latest data)
- Kinds of cards
- Operation date and time (Month / day hour : minute)
- Error code
- Error content (Plurality of lines displayed sometimes)
- Maintenance code
- Next error log (from the latest old data)

:

Concerning the contents of the error, please refer to [■ Error codes and corrective actions]

※ When there is no log data within the designated search area, ERROR shall be displayed.



Press the **[ITEM RE - SEL.]** key and the display reverts to 3. 1. 2 (1).

### 3. 1. 3 Printing out the error log

When an exclusive printer is connected, while the error log data is being displayed, if the **[PRINT]** key is pressed, the printer shall print out the data.

(1) During the printing, the following is displayed.



When the printing is ended, the display reverts to error log data.

※ The power source for the printer is turned on after the power source for the DTU is turned on.

<<Example of printing>>

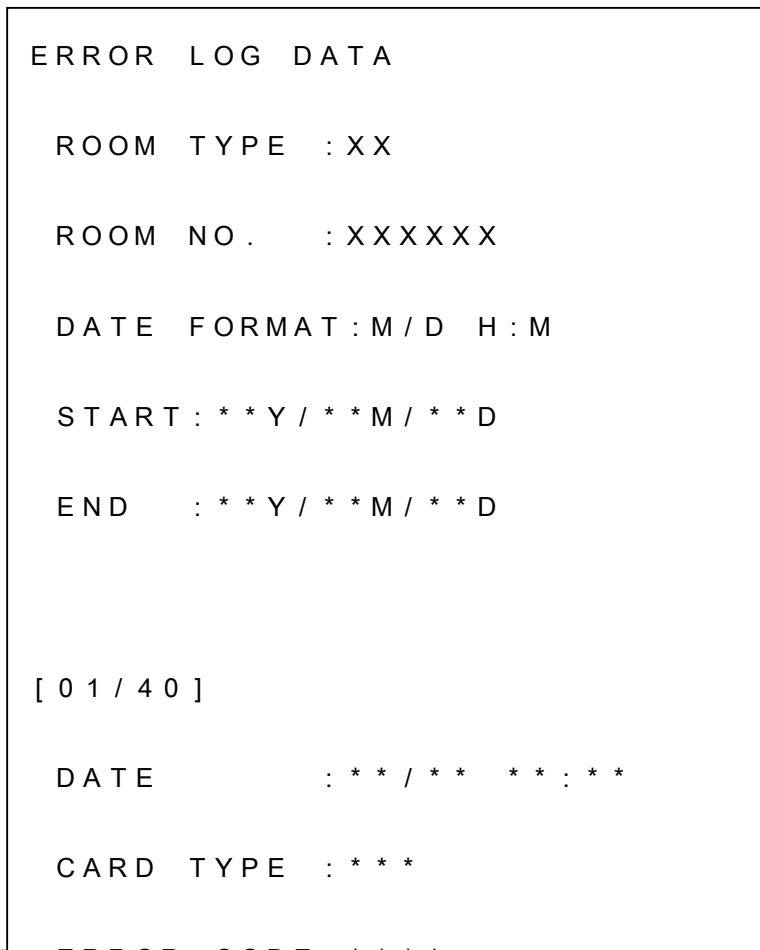

### 3.2 Interrogation data

The card lock has recorded on hand a maximum 600 items of the latest interrogation data. Using the DTU, interrogation data can be referred to. Furthermore data up to a maximum 16 rooms (card lock) can be recorded.

#### 3.2.1 Transmission of interrogation data

Interrogation data from the card lock is transmitted to the DTU.

- (1) The main menu is displayed.

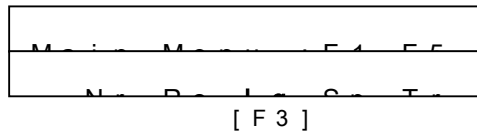

Press the **[F3]** key.

- (2) The log mode menu is displayed.

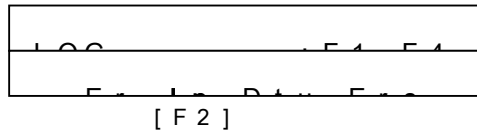

Press the **[F2]** key.

- (3) The interrogation data display is shown.  
The last interrogation mode item processed the preceding time in interrogation made is displayed together with the data storage number and its contents.

When data is already in storage.....Room Type or Room No. (in the case of guest room)

SELECT DATA No.
01-000101

When storage is EMPTY

SELECT DATA No.
01-EMPTY

When storage is EMPTY, transmission of the interrogation data is feasible.

- ※ When data has already been transmitted to a storage destination, data for storage cannot be transmitted from the card lock. Select another viable data storage number.  
When referring to data already placed in storage, press the **[ENTER]** key and the unit will proceed to 3. 2. 2 Confirmation of interrogation data.

- (4) Select an empty storage number between 01 and 16.  
Example) When placing storage, interrogation data in storage No. 10.

SELECT DATA No.
01-000101

Press the **[▲]** **[▼]** key.

The storage No. 10 is displayed.

SELECT DATA No.
10-EMPTY

Press the **[ENTER]** key.

- (5) The data transmission confirmation display is shown.



The infrared ray sensor (IrDA) of the DTU is aimed at the infrared ray sensor (IrDA) of the card lock and then the **[SEND / RCV]** key is pressed.

Prior to pressing the **[SEND / RCV]** key, if the **[ITEM RE - SEL.]** key is pressed, the display reverts to the log menu 3. 2. 1 (2).

- (6) Data is transmitted from the DTU to the card lock.  
During transmission, the following is displayed.  
(When the transmission time is short, sometimes there is no display.)

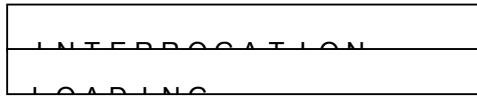
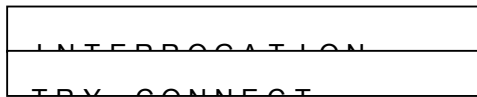

← Intermittent blinking (During transmission)

When the transmission ends normally, the following is displayed.



Press the **[ENTER]** key.

After transmission of data, the infrared ray sensor (IrDA) of the DTU can be separated from the infrared ray sensor (IrDA) of the card lock without causing any trouble.

- (7) After transmission, the interrogation data selection display is shown.

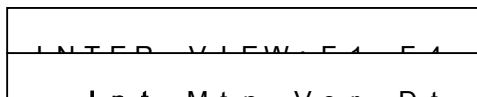

※ Any failure in transmission displays ERROR.

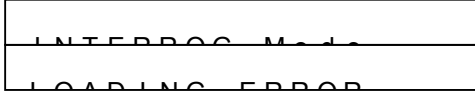

When no data at all was transmitted, press the **[ERROR RESET]** key and the display reverts to 3. 2. 1 (5).

When transmission of data became impossible during transmission, **[ERROR RESET]** key is pressed and the unit progresses to 3. 2. 1 (7) but data cannot be confirmed.

※ Any failure in transmission displays ERROR.

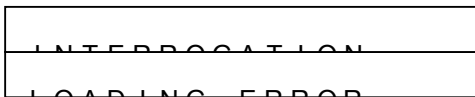

When no data at all was transmitted, press the **[ERROR RESET]** key and the display reverts to 3. 2. 1 (5).

When transmission of data became impossible during transmission, **[ERROR RESET]** key is pressed and the unit progresses to 3. 2. 1 (7) but data cannot be confirmed.

※ In the case of a hotel code check error, the following is displayed.

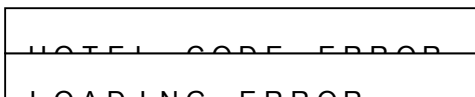

Pressing the **[ERROR RESET]** key, reverts the display to 3. 2. 1 (5).

### 3. 2. 2 Confirmation of interrogation data

Interrogation data that has been transmitted, is searched and its contents confirmed.

- (1) When transmission has been completed, the interrogation data selection display is shown.

```

INTERVIEW: F1 F1
SEARCH: YES NO
  
```

[ F 1 ]

Press the **[F1]** key.

In the interrogation data mode of the 3. 2. 1 (3) display, this is also displayed when the storage number is selected for already transmitted data.

- (2) Data search display is shown.  
 Today's date is also displayed.  
 Example) When the current date is June 30, 2003,  
 if this is satisfactory as is, press the **[ENTER]** key.

When the searching date is designated, input the date.

Example) When the search commencement date is June 28, 2003:

```

GET DATE RANGE
SEARCH: YES NO
  
```

Press the **[0] [3] [0] [6] [2] [8]** keys.

```

GET DATE RANGE
SEARCH: YES NO
  
```

→ 030628 is displayed.

Press the **[ENTER]** key.



Example) When the end of searching date is June 30, 2003:

← SET DATE RANGE
→ 00Y/06M/00D

Press the **[0] [3] [0] [6] [3] [0]** keys.

← SET DATE RANGE
→ 030630

→ 030630 is displayed.

Press the **[ENTER]** key.

- (3) As a plurality lines of text are involved, press the **[▲]** **[▼]** keys for a scrolling display.

The contents of the interrogation data is displayed.

Within the designated limits of the search, data will be displayed starting from the latest data.

Example) Number of items / total number and the kinds of cards are displayed.

← ENTER 1001/6001
→ CARD CH

Press the **[▼]** key.

The operation date and unlocking flag is displayed.

→ **M/**D** **
← SET

Press the **[▼]** key.

The summer time flag is displayed.

← LOCK/UNLOCK
→ SUMMER T-RESET

Press the **[▼]** key.

The succeeding interrogation data contents is displayed. (a maximum 600 items are displayed.)



While the interrogation data is being displayed, if the [ITEM RE - SEL.] key is pressed twice, the display reverts to the interrogation data storage No. selection display 3. 2. 1 (4).

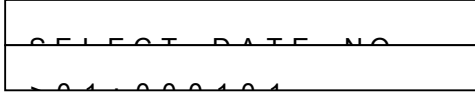

With the interrogation data storage No. selection display, if the [ITEM RE - SEL.] key is pressed, the display reverts to the log mode menu.

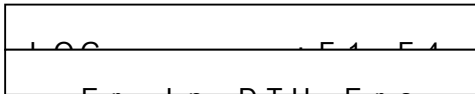

<<An example of interrogation data>>

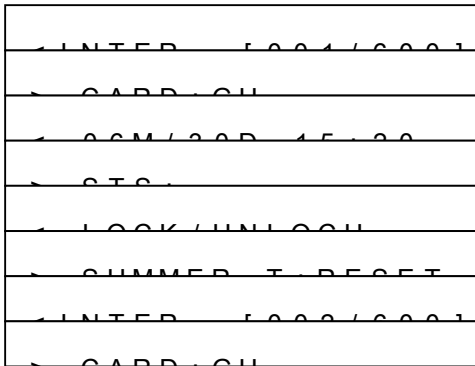

Number of items / Total items (of the latest data)

The kinds of cards

Operation date (Month / day / hour / minutes)

Unlocking flag (※)

Summertime flag

Following data (1 notch older data)

※ Unlocking flag

NO USE : as yet unused

UNLOCK : unlocking the lock

LOCK : locking the lock

LOCK / UNLOCK : Locking the lock /  
Unlocking the lock

※ Within the range designated for the search, when interrogation data is not found, ERROR shall be displayed.

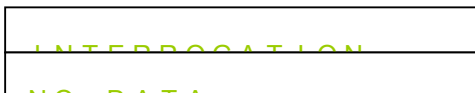

If the **[ITEM RE - SEL.]** key is pressed, the display reverts to 3. 2. 2 (1).

### 3. 2. 3 Printing the interrogation data

When there is an exclusive printer connected, while the interrogation data is displayed, pressing the **[PRINT]** key results in the printer printing out the interrogation data.

(1) During printing, the following is displayed.



When printing is completed, the display reverts to the interrogation data display.

※ The power for the printer is turned on after the DTU power has been turned on.

<<Example of printing>>

```

INTERROGATION DATA

ROOM TYPE : * *

ROOM NO . : * * * * *

DATE FORMAT : M / D H : M

START : * * Y / * * M / * * D

END   : * * Y / * * M / * * D

[ 0 0 1 / 6 0 0 ]

DATE       : * * / * * * * : * *

CARD TYPE : * * *

LOCK STS  : * * * * *

```

### 3.3 Erasing of the log

Error log or if the interrogation data, a maximum 16 rooms worth (card lock) data is recorded. When log data of the 17th room is to be recorded anew, it becomes necessary to erase other previous log data. (When the log data is erased, the error log and interrogation data is completely erased.)

- (1) The log mode menu is displayed.

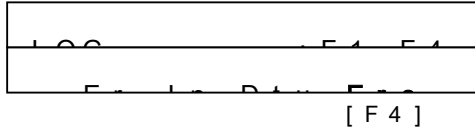

Press the **[F4]** key.

- (2) The log data erasing confirmation display is shown.

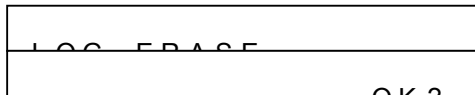

- (3) <<When log data is to be erased>>

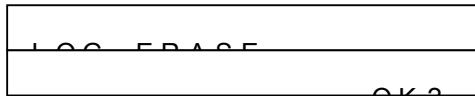

Press the **[ENTER]** key.

All of the log data is erased.

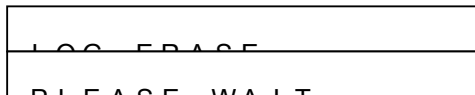

Erasing data takes a little time.

The display reverts to the log mode menu.

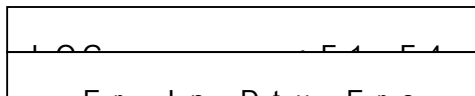

(4) <<When log data is not to be erased>> (

LOG ERASE
OK

Press the [ITEM RE - SEL.] key

Display returns to log mode menu.

LOG	F4	F4
Erased Data	F4	F4

## 4 Special mode

In an emergency, it is possible without using any cards, to transmit signals from the DTU to the card lock and unlock or cancel lockout instructions and unlock card locks.

Operations are conducted from the main menu.

### 4.1 Emergency reset (EMG RESET)

In the emergency, after EMG OPEN or after using the EM card, maintaining the compulsory unlocked position is RESET.

#### 4.1.1 Transmit the RESET signal

The signal is transmitted from the DTU to the card lock.

- (1) The main menu is displayed.

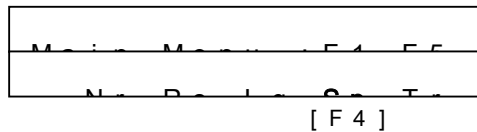

Press the **[F4]** key.

- (2) The special mode menu is displayed.

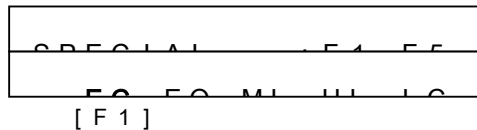

Press the **[F1]** key.

- (3) The data transmission confirmation display is shown.

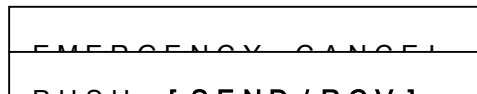

The infrared ray sensor (IrDA) of the DTU is aimed at the infrared ray sensor (IrDA) of the card lock and the **[SEND / RCV]** key is pressed.

Prior to pressing the **[SEND / RCV]** key, if the **[ITEM / RE - SEL.]** key is pressed,

the display reverts to the special mode menu 4. 1. 1 (2).

- (4) Data is transmitted from the DTU to the card lock.  
During transmission, the following display appears.  
(When transmission is only for a short time, the display may not appear.)

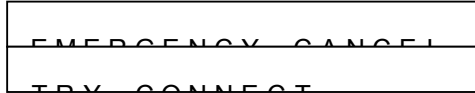

EMERGENCY CANCEL  
TRY CONNECT

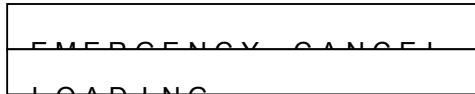

EMERGENCY CANCEL  
LOADING

When transmission normally ends, the following is displayed.

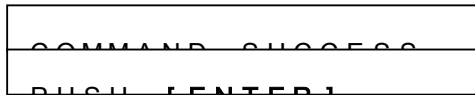

COMMAND SUCCESS  
PUSH ENTER

Press the **[ENTER]** key.

After transmission of data the infrared ray sensor (IrDA) of the DTU may no longer be confined to the card lock infrared ray sensor (IrDA) of the card lock.

※ When failing to transmit, **ERROR** is displayed.

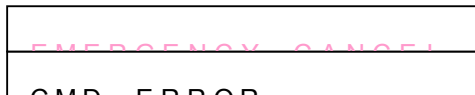

EMERGENCY CANCEL  
CMD ERROR

Press the **[ERROR RESET]** key and the display will revert to 4. 1. 1 (2).

## 4.2 Emergency OPEN (EMG OPEN)

In an emergency, the card lock is placed in EMG OPEN position (maintained compulsorily unlocked).

When holding the lock in a compulsory unlocked position, the battery is quickly drained so that after resetting EMG, always be sure to replace the battery.

To RESET an EMG OPEN, follow 4.1 EMG RESET or follow the operation outlined for DEAD BOLTing the card lock.

### 4.2.1 Transmit the OPEN signal

The signal is transmitted from the DTU to the card lock.

- (1) The main menu is displayed.

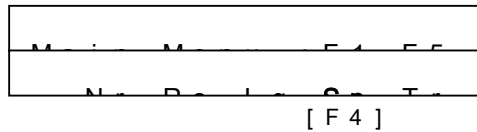

Press the **[F4]** key.

- (2) The special mode menu is displayed.

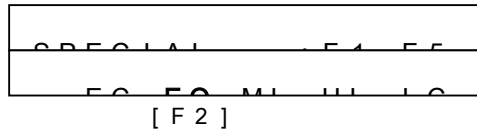

Press the **[F2]** key.

- (3) The data transmission confirmation display is shown.

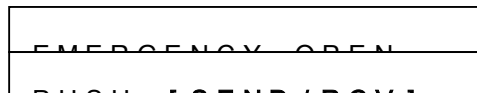

The DTU infrared ray sensor (IrDA) is aimed at the card lock infrared ray sensor (IrDA) and the **[SEND / RCV]** key is pressed.

Prior to pressing the [SEND / RCV] key, if the **[ITEM RE - SEL.]** key is pressed, the display reverts to the special mode menu 4. 2. 1 (2).

- (4) Data is transmitted from the DTU to the card lock.  
During transmission the following display appears.  
(When the transmission is short, sometimes this display is not shown.)

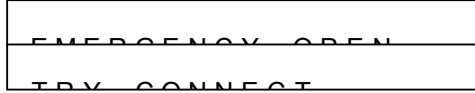

EMERGENCY OPEN  
TRY CONNECT

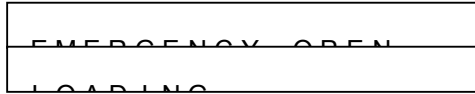

EMERGENCY OPEN  
LOADING

When transmission normally ends, the following is displayed.



COMMAND SUCCESS  
PUSH ENTER

Press the **[ENTER]** key.

After transmission, the DTU infrared ray sensor (IrDA) may be separated from the card lock infrared ray sensor (IrDA) without any further trouble.

※ When failing to transmit, **ERROR** is displayed.

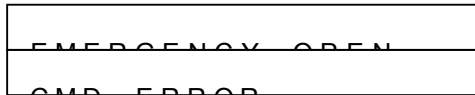

EMERGENCY OPEN  
CMD ERROR

Press the **[ERROR RESET]** key and the display reverts to 4. 2. 1 (2).

### 4. 3 MASTER LOCKOUT (ML)

The GUA, GUB, MT, ST, MS, and MS cards are in LOCKOUT position.

To cancel the LOCKOUT, either conduct the 4.5 LOCKOUT CANCEL or use the CL card.

#### 4. 3. 1 Transmit the LOCKOUT signal

The signal is transmitted from the DTU to the card lock.

- (1) The main menu is displayed.

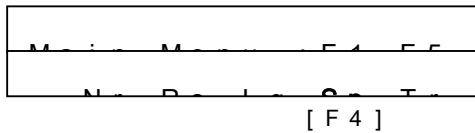

Press the **[F4]** key.

- (2) Special mode menu is displayed.

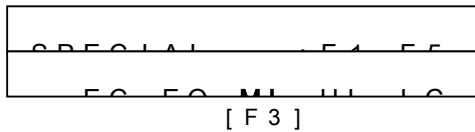

Press the **[F3]** key.

- (3) The data transmission confirmation display appears.

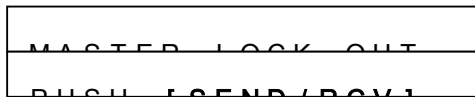

The DTU infrared ray sensor (IrDA) is aimed at the card lock infrared ray sensor (IrDA) and the **[SEND / RCV]** key is pressed.

Prior to pressing the **[SEND / RCV]** key, if the **[ITEM RE - SEL.]** key is pressed, the display reverts to 4. 3. 1 (2).



- (4) The data is transmitted from the DTU to the card lock.  
During transmission the following is displayed.  
(If the transmission time is short, the display may not appear.)

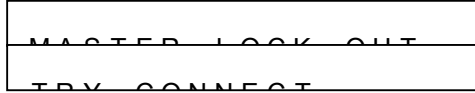

MASTER LOCK OUT  
TRY CONNECT

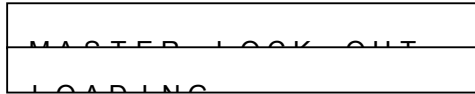

MASTER LOCK OUT  
LOADING

When transmission normally ends, the following is displayed.



COMMAND SUCCESS  
PUSH ENTER

Press the **[ENTER]** key.

After transmission of data, the DTU infrared ray sensor (IrDA) may be separated from the card lock infrared ray sensor (IrDA) without any further trouble.

※ When failing to transmit, ERROR is displayed.

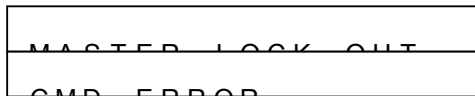

MASTER LOCK OUT  
CMD ERROR

Press the **[ERROR RESET]** key and the display reverts to 4. 3. 1 (2).

#### 4. 4 HOUSEKEEPING LOCKOUT (HL)

The GUA, GUB, and ST cards are in LOCKOUT position.

To cancel the LOCKOUT status, undertake the 4.5 LOCKOUT CANCEL or use the CL card.

##### 4. 4. 1 Transmit the LOCKOUT signal

The signal is transmitted from the DTU to the card lock.

- (1) The main menu is displayed.

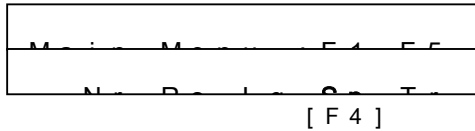

Press the **[F4]** key.

- (2) The special mode menu is displayed.

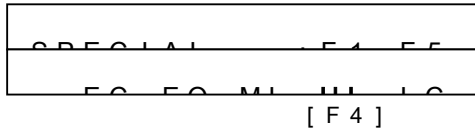

Press the **[F4]** key.

- (3) The data transmission confirmation is displayed.

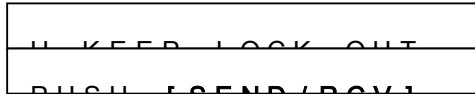

The DTU infrared ray sensor (IrDA) is aimed at the card lock infrared ray sensor (IrDA) and the **[SEND / RCV]** is pressed.

Prior to pressing the **[SEND / RCV]** key, pressing the **[ITEM RE - SEL.]** key causes the display to revert to the special mode menu 4. 4. 1 (2).

(4) The data is transmitted from the DTU to the card lock.

During transmission the following is displayed.

(When the transmission time is short, sometimes the display does not appear.)

MASTER LOCK OUT  
TRY CONNECT

MASTER LOCK OUT  
LOADING

When transmission is normally ended, the following is displayed.

COMMAND SUCCESS  
PUSH [ENTER]

Press the **[ENTER]** key.

After data transmission, the DTU infrared ray sensor (IrDA) may be separated from the card lock infrared ray sensor (IrDA) without any further trouble.

※ When failing to transmit, **ERROR** is displayed.

MASTER LOCK OUT  
CMD ERROR

Press the **[ERROR RESET]** key and the display reverts to 4. 4. 1 (2).

## 4.5 LOCKOUT CANCEL (LC)

The HOUSEKEEPING LOCKOUT and MASTER LOCKOUT statuses are canceled.

### 4.5.1 Transmission of the cancellation signal

The signal is transmitted from the DTU to the card lock.

- (1) The main menu is displayed.

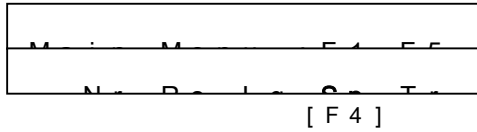

Press the **[F4]** key.

- (2) The special mode menu is displayed.

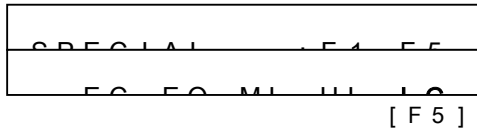

Press the **[F5]** key.

- (3) The data transmission confirmation is displayed.



The DTU infrared ray sensor (IrDA) is aimed at the card lock infrared ray sensor (IrDA) and the **[SEND / RCV]** key is pressed.

Prior to pressing the **[SEND / RCV]** key, if the **[ITEM RE - SEL.]** key is pressed, the display reverts to special mode menu 4.5.1 (2).

- (4) Data is transmitted from the DTU to the card lock.  
During transmission the following is displayed.  
(When transmission time is short, sometimes this is not displayed.)

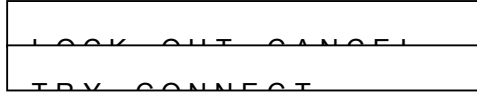

LOCK OUT CANCEL  
TRY RECONNECT

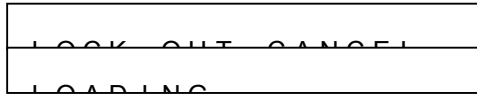

LOCK OUT CANCEL  
LOADING

When transmission normally ends, the following is displayed.



COMMAND SUCCESS  
PUSH ENTER

Press the **[ENTER]** key.

After data transmission, the DTU infrared ray sensor (IrDA) may be separated from the card lock infrared ray sensor (IrDA) without further trouble.

※ When failing to transmit, **ERROR** is displayed.

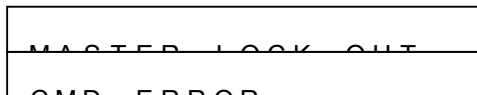

MASTER LOCK OUT  
CMD ERROR

Press the **[ERROR RESET]** key and the display reverts to 4. 5. 1 (2).

## 5 Data transmission mode

Interrogation data that has been input into the DTU may be transmitted to the card issuing control.

### 5.1 Transmission of interrogation data

#### 5.1.1 Transmission of data

Data is transmitted from the DTU to the card issuing control.

- (1) Main menu is displayed.

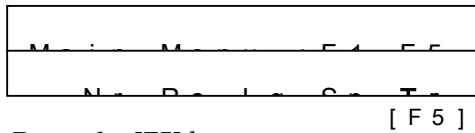

Press the **[F5]** key.

- (2) The data transmission mode menu is displayed.



Press the **[SEND / RCV]** key.

Prior to pressing the [SEND / RCV] key, pressing the [ITEM RE - SEL.] key results in the display reverting to data transmission mode menu 5. 1. 1 (1).

- (3) Data is transmitted from the DTU to the card issuing control.

During transmission, the following is displayed.

(When the transmission time is short, sometimes the display is not shown.)

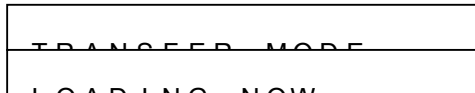

After data transmission ends, or you wish to temporarily suspend transmission, if the **[ITEM RE - SEL.]** key is pressed, the display reverts to the main menu 5. 1. 1 (1).

Regarding further operations of the card issuing control, please refer to "The Maintenance Manual of the PC Model Card Issuing Control".

Error Code	Screen	Cause		Action
0x01	READ ERROR	Read fails	Card reading fails	Redo Clean head Replace reader
0x03	CRC ERROR	CRC fails	Mag-card reading fails (Decoding fails )	Clean head Reissue card Replace reader
0x04	READ TIME OUT	Read time-out	No mag-data No IC card communicates Slot sensor only ON	Redo Reissue card Replace reader
0x05	DISAGREEMENT HOTEL CODE	No matching hotel code	Wrong hotel code	Use card issued by the hotel
0x06	CARD CLASS ERR	Card class error	Card not compliant	
0x09		Writing history fails	Writing history on IC card fails	Use another card
0x0A	ALGORITHM ERR	Algorithm error (Sequence error)	Card of lower sequence than before is used.	Use newer card than before
0x0B	USE FOR DEADBOLT	Dead bolt being triggered	Dead bolt being triggered	Pull back dead bolt
0x0C	DURING MS LOCK OUT	MS being locked out	Card passed while master being locked out	Release lock-out
0x0D	DURING HK LOCK OUT	HK being locked out	Card passed while house-keeping being locked out	Release lock-out
0x0E	INVALID CARD	Card not compliant	Card inserted with unauthorized door type	Re-issue card
0x0F	DURING SHUTOFF	Being shutting out	Card passing while shutting out	Release shut-out
0x10	DISAGREEMENT ROOM	Wrong room	Wrong guest room	Issue card for the guest room
0x11	OUT OF ROOM RANGE	Out of room range	Wrong room range	Issue card for the guest room
0x12	DISAGREEMENT NonGUEST ROOM No.	Wrong guest door flag	wrong guest door	Issue card for the guest room

■ Error codes and corrective actions

Error code	Screen	Cause		Action
0x13	OUT OF TIME FOR GUEST USE	Out of time for guest use	Wrong time for use	Check lock time Issue guest card
0x14	OUT OF WEEK FOR GUEST USE	Wrong day of week for guest	Wrong day of week	Check lock time Issue guest card
0x15	OUT OF VALI -DATE RANGE FOR STAY	Out of valid stay range	Out of valid time	Check lock time Issue guest card
0x16	USE INVALIDATE CARD	Invalid card	Invalid card used for lock	Re-issue card
0x18	COMMON USE ERR (ISSUE DAY)	Invalid common use (issue date)	Invalid date of issue for common use	Re-issue card
0x1A	ERROR USE TERM OF VALIDITY	Invalid term	Term of Mtexpires	Re-issue card
0x1B	OPERATION ERR DAYLIGHTSAVING CARD	DS Operation error	Failure in setting or restting day-light saving	Operate during hours other than 23:00 to 1:00
0x20	OUT OF THE TERM OF VALI -DITY SMS	Out of valid SMS time	Card inserted out of valid time	Check lock time Check SMS use time
0x21	OUT OF THE TIME OF VALI -DITY SMS	Out of valid SMS time	Card inserted out of valid time	Check lock time Check SMS use time
0x22	OUT OF THE WEEK OF VALI -DITY SMS	Out of SMS's valid day of week	Card inserted out of valid day of week	Check lock time Check SMS use time
0x23	DISAGREEMENT LOCK OFF CONDITION	SMS's unlockikng condition not agree	Unlocking not possible due to wrong unlocking condition	Check data on card
0x2A	WRONG CODE SEQUENCE	Wrong code sequence	Wrong sequence code	Re-issue card
0x2B	WRONG CODE DATE	Wrong code Date	Wrong date code	Re-issue card
0x2C	WRONG CODE TIME	Wrong time code	Wrong time code	Re-issue card
0x2D	WRONG CODE ROOM NO	Wrong room No. code	Wrong room No. code	Re-issue card
0x2E	WRONG CODE SMS LEVEL	Wrong SMS level code	Wrong SMS level code	Re-issue card
0x2F	WRONG CODE CHECK IN-OUT	Wrong CK-IN/OUT code	Wrong date code of C/CO	Re-issue card

Error code	Screen	Cause		Action
0x31	WRONG RANGE SMS COMMAND	WRONG RANGE SMS COMMAND	Wrong command code of SMS	Re-issue card
0x32	WRONG RANGE DISPOSE CODE	Wrong range code	Wrong code of DS card	Re-issue card

### ■ Cleaning up maintenance

- Normally wipe with soft cloths.
- When soiling becomes acute, wipe off with soft cloths squeezes after being immersed in solutions of diluted kitchen cleansers.
- Never use any of the following because of possible damage to equipment.
- Powdered cleansers / polishing powders / benzene / thinners / waxes / gasoline / boiling water
  - ※ When using chemical wipers, please follow their detailed instructions.

### ■ Components specifications

Name	DTU
Type	AL5HDTU1
Normal Use Temperature and Humidity	+5°C~+40°C / 30~80% RH or less (no condensation)
Storage Temperature and Humidity	-20°C~+60°C / 15~90% RH or less (no condensation)
Size	110mm(W)×200mm(H)×50.5mm(D)
Weight	About 0.5Kg
Material	ABS Resin
Power Source	AC100V~AC240V±10% 50/60Hz Power consumption 30VA

### ■ Where to contact the manufacturers

In addition to our head office, branches and business offices in the major cities of Japan, and also our sales agents and servicing agencies, we have a country wide network.

From receiving your orders to final delivery, and including servicing, speedily anywhere you may desire, we are ready to provide you with anything you wish.